

Optical Sensor Reduces Maintenance Costs



Green glow is simulated

Model Q45D-ODO

Optical Dissolved Oxygen Monitor

Dissolved Oxygen monitoring is critical for aeration system process control. Optimization of the biological process, whether it be carbonaceous removal, nitrification, or nitrification/denitrification, depends on maintaining proper D.O. levels. In addition, controlling blowers and aerators to operate at optimal level eliminates excess aeration and will result in large power savings for the plant.

ATI's Series Q45D has been providing reliable D.O. control in plants throughout the world for many years. Using a galvanic membraned sensor, this system is a proven performer in the most demanding applications.



The Auto-Clean D.O. Monitor

Now, the Q45D is being upgraded with the addition of a new optical dissolved oxygen sensor that reduces maintenance to a new low. Based on fluorescence quenching technology, this sensor provides continuous D.O. monitoring with virtually no service, and still provides the reliability inherent with the Q45D automatic sensor cleaning system.



Dissolved Oxygen Monitor

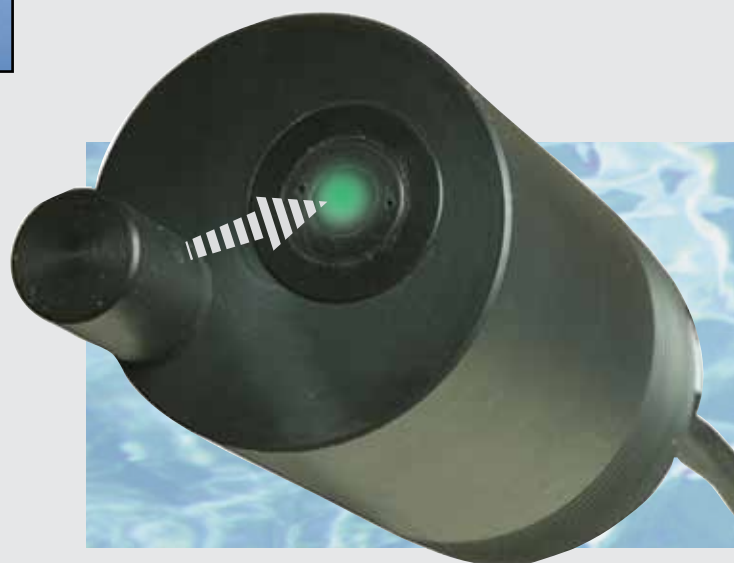

Optical D.O. sensor with optional air blast cleaning

Model Q45D-ODO

Optical Dissolved Oxygen Monitor

Low Maintenance & Reliable Performance

Optical D.O. sensors developed in the last few years use a technique that essentially measures the rate at which oxygen absorbs an optical signal generated within a membrane impregnated with a fluorescent dye. The dye within the optical element is excited by a pulse of light from an internal LED. This causes the dye to fluoresce, or emit light of a different wavelength. The rate at which this emitted light decays (or is “quenched”) is proportional to molecular oxygen in the element. The higher the oxygen level, the faster the decay rate.

Optical sensors do not have internal electrolyte, so maintenance on this type of sensor is limited to changing the optical element. ATI's optical element is designed to last a minimum of 2 years in normal operation, but will more often provide a life of 3-5 years unless mechanical damage occurs. Optical sensors also do not require flow across the sensor so measurements can be made more accurately in systems with low flows. Unlike some optical sensors, this sensor is not degraded by exposure to sunlight.

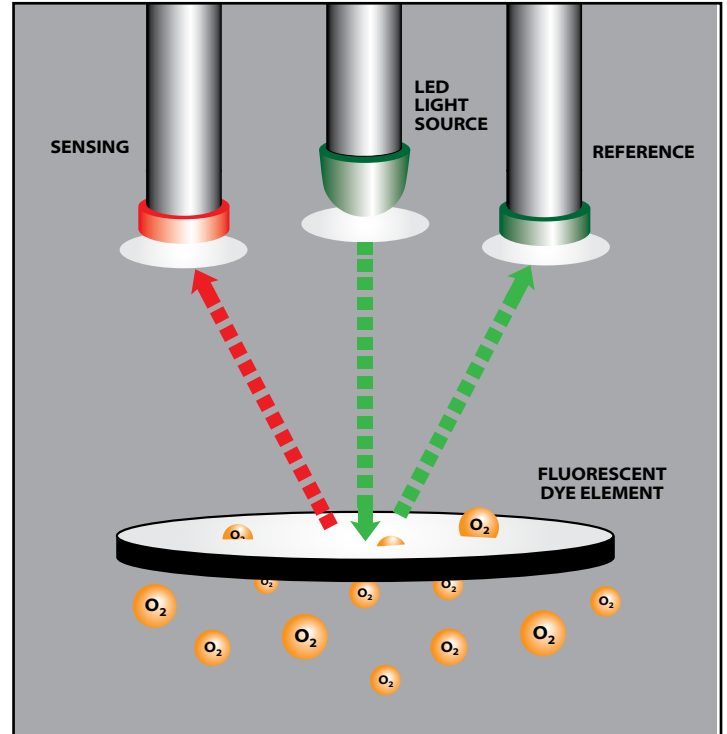

Sensor Operation

Handrail Installation

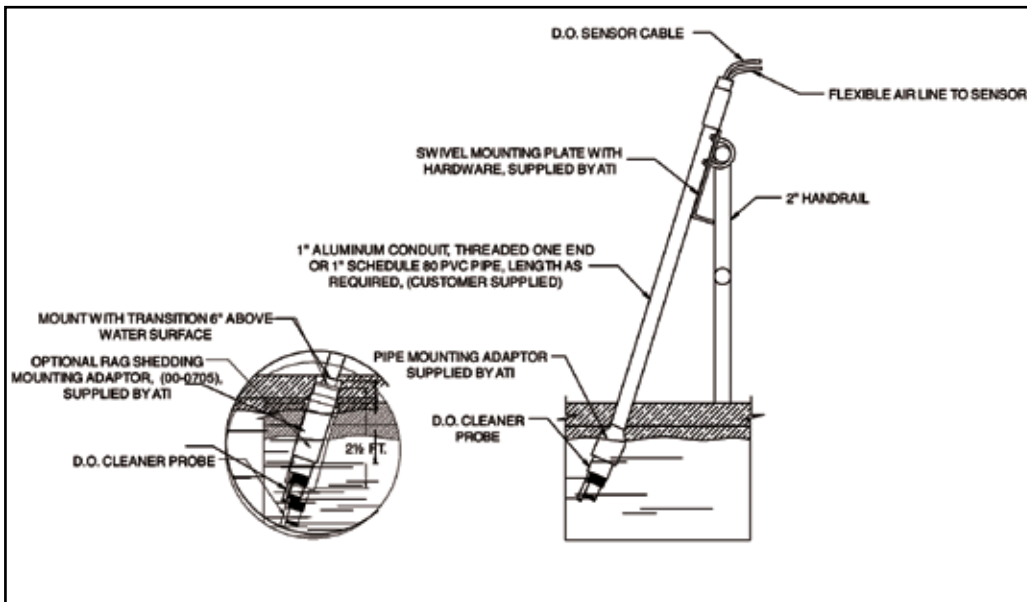

The Q45D-ODO Auto-Clean D.O. system is supplied complete with all measurement and air cleaning components conveniently packaged in a single enclosure. All that's needed for installation is connection of AC power and hookup of the D.O. sensor cable and sensor air tube. Sensors are mounted to a 1" support pipe with a quick-release mounting assembly to allow for easy inspection. Even a separate alarm relay is available to signal operators in the event that the air cleaning system requires attention.

Q45 Specifications

Measurement Type:	Dissolved Oxygen
Sensor Type:	Optical fluorescence quenching
Range:	0-40.00 mg/l (or PPM) 0-200% Saturation
Response Time:	90% in 150 seconds
Accuracy:	± 0.05 PPM below 2 PPM
Repeatability:	± 0.2 PPM from 2-10 PPM, ± 0.4 PPM above 10 PPM
Electronic Linearity:	± 0.5%
Zero Drift:	< 1% full scale per month, non-cumulative
Display:	Backlit LCD, 0.5" Main Display
Controls:	4 membrane switches on front of monitor
Outputs:	Two Isolated 4-20 mA, 575 ohms maximum
Alarm Relay:	Two SPDT, 5 A @ 230 VAC resistive
Relay Coil:	Programmable either normally energized or normally de-energized
Optional Alarm:	Cleaner system failure alarm
Power:	115 or 230 VAC, 50/60 Hz, 5 VA max.
Sensor Operating Temp.:	0 to 50° C
Monitor Operating Temp.:	-20 to +60° C (-40° C with optional heater)
Sensor Cable:	30 ft. (10 m) standard
Humidity:	0-95% Non-condensing
Weight:	10 lbs. (4.5 Kg.)



Analytical Technology, Inc.
6 Iron Bridge Drive, Collegetown, PA 19426
Phone: (610) 917-0991
Toll-Free: 800-959-0299
Fax: (610) 917-0992
E-Mail: sales@analyticaltechnology.com

Analytical Technology
Technology House,
Gatehead Business Park
New Delph Road, Saddleworth OL3 5DE
Phone: +44 (0) 1457 832800
Fax: +44 (0) 1457 839500
E-Mail: sales@atiuk.com

www.analyticaltechnology.com

Represented By:

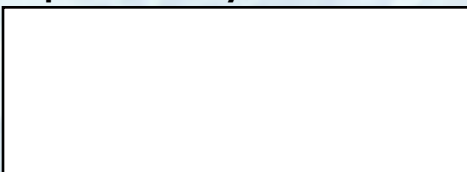

Ordering Information Model Q45-A-B-C-D-E D.O. Monitor

Suffix A: Power

- 1 - 24 VDC, 2-wire (Single Output Only)
- 2 - 115 VAC with 2 Relays & 2 Outputs
- 3 - 230 VAC with 2 Relays & 2 Outputs
- 4 - Portable Battery with two 0-2.5 V Outputs
- 5 - Portable Battery with internal data logger & software
- 6 - 115 VAC Auto-Cleaner
- 7 - 230 VAC Auto-Cleaner

Suffix B: Sensor Type

- 6 - Optical D.O. sensor with cleaner nozzle, 30ft. (10m.) cable

Suffix C: Membrane Type

- 3 - Not applicable for optical sensor

Suffix D: Enclosure Heater (Available for Auto-Clean Systems Only)

- 1 - No Heater
- 2 - Heater/Thermostat (For ambient temperature below 10° F)

Suffix E: Cleaner Fail Alarm (Available for Auto-Clean Systems Only)

- 1 - No Alarm
- 2 - With Cleaner Fail Alarm Systems